

Adjustments

⚠ Warning!

Before driving, always make sure that the basic settings made by Öhlins are according to recommended Set-up Data. Read about adjustments and setting up in the Öhlins Owner's Manual before you make any adjustments. Contact an Öhlins dealer if you have any questions about setting up the shock absorber.

Set-up Data

Recommended set-up

Rebound 10 clicks
Shock absorber length 529 mm

Spring

Spec H250, ID65-95, 24-65 N/mm

The actual vehicle height

The vehicle is lowered approximately 30 mm when compared to the original suspensor. As the length adjuster is turned one rotation, the position moves 1.5 mm.

⚠ Warning!

The adjustment range is the standard position ± 15 mm. If the bracket is moved outside the adjustment range, it may come loose.

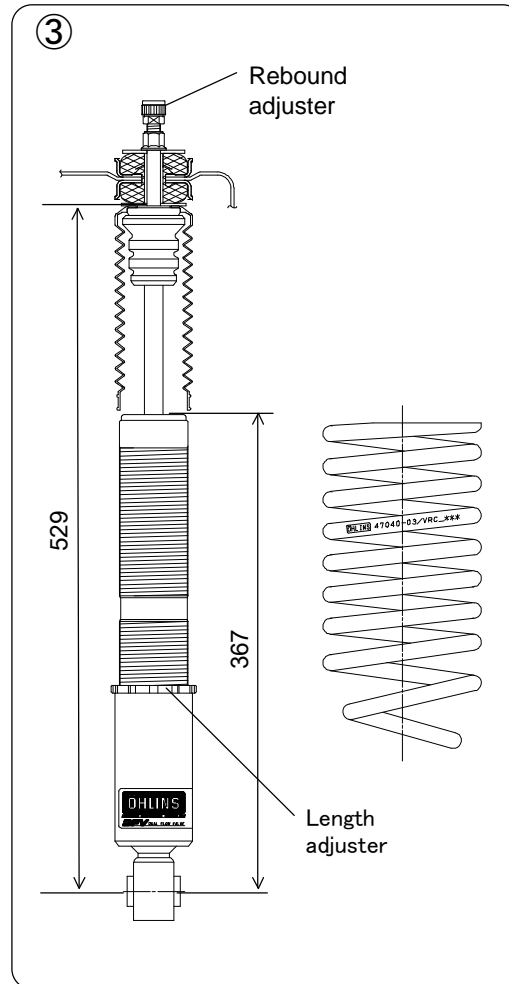

Before installing this product, check the contents of the kit. If anything is missing, please contact an Öhlins dealer.

Kit Contents	Pcs.
Shock absorber	2
Dust boot	2
Spring	2
Washer	2
Bushing spacer ID12	2
Spacer ID10	2

MOUNTED ON SHOCK ABSORBER
Adjuster 2

USED FOR BOTH FRONT AND REAR

C-spanner	1
C-spanner	1
Öhlins sticker	1
Öhlins Owner's Manual	1

Please note that during storage and transportation, especially at high ambient temperature, some of the oil and grease used for assembling may leak and stain the packaging. This is in no way detrimental to the product, wipe off the excess oil/grease with a cloth.

⚠ Warning!

Before installing this product, read the Öhlins Owner's Manual. The shock absorber is an important part of your vehicle and will affect the stability.

Öhlins products are subject to continuous improvement and development, therefore, although these instructions include the most up-to-date information available at the time of printing, minor updates may occur.

To find the latest information contact your Öhlins distributor. Please consult your Öhlins dealer if you have any questions regarding the contents in this document.

Part no. HOSMI30.0
Issued 2010-12-24



Shock Absorber Kit for Honda Civic type R (FD2)

HOS MI30 rear

Mounting Instructions

© Öhlins Racing AB. All rights reserved. Any reprinting or unauthorized use without the written permission of Öhlins Racing AB is prohibited.

Öhlins Racing AB



www.ohlins.com



How to install

▲ Warning!

It is advisable to have an Öhlins dealer install the shock absorber.

When installing, read your Vehicle Service Manual.



1

Raise the vehicle and put it on jack stands.

▲ Warning!

Ensure that it is securely supported.

2

Remove the rear wheels.

3

Remove the lower and the upper attachments and remove the original shock absorbers.

☞ Caution!

Support the lower arm with the jack before removing the damper. Otherwise, when the damper is removed, the lower arm rapidly falls.

4

Remove the springs.

5

Install the Öhlins springs on the vehicle.

6

Fit the dust boot, the washer, the std rubber bushes and the spacer according to fig①.

7

Install the Öhlins shock absorbers on the vehicle according to fig②.
Tighten the std nut to 20 Nm.

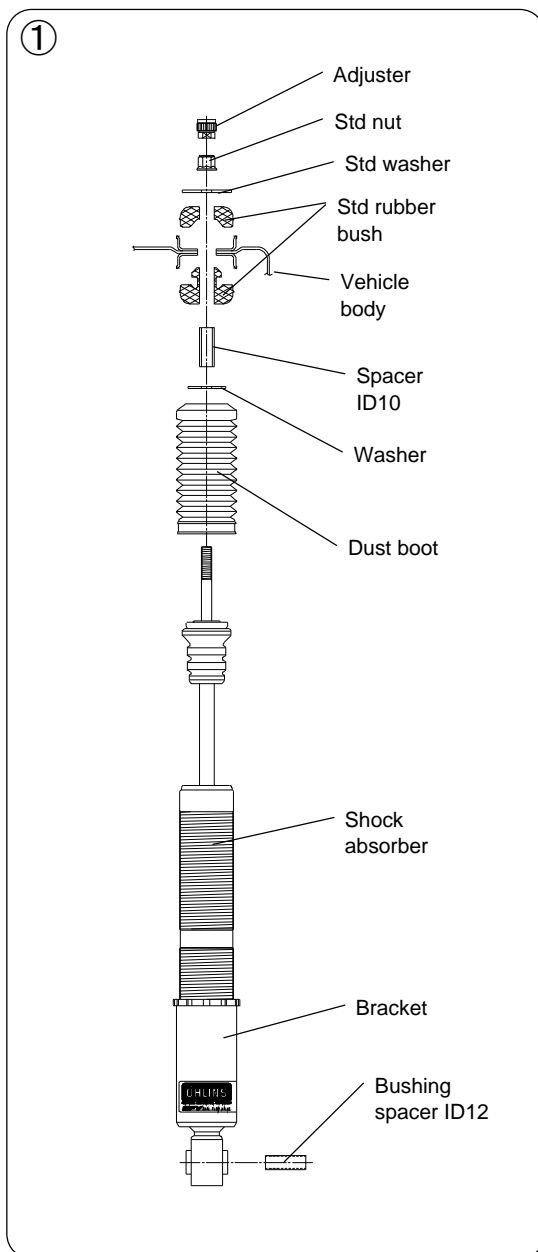

👁 Note!

When tightening the top mount nut, the shock absorber shaft must be held in position with a 5 mm Allen key.

👁 Note!

Make sure that all bolts are tightened to the correct torque and that nothing fouls or restricts movement of the shock absorber when it is being fully compressed or extended.

8

Make sure that all removed parts are reinstalled in the same way as they were before the installation of the Öhlins shock absorber.

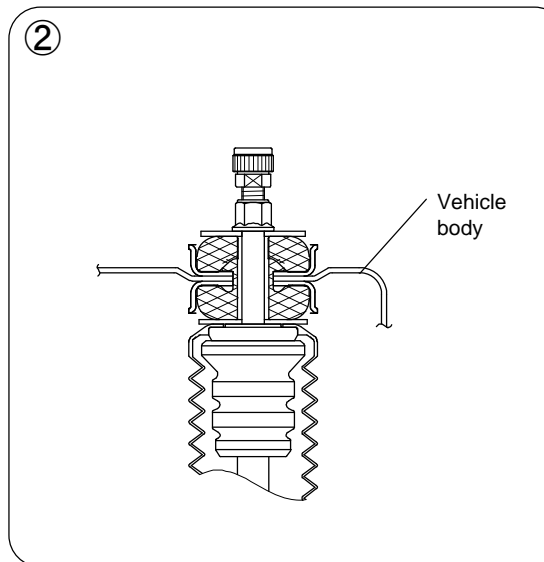

How to install